

INSTALLATION INSTRUCTIONS EH SERIES ELECTROMAGNETIC DOOR HOLDER

ELECTRICAL

This product is a high quality electromagnetic holding device intended for use in fire door applications, but can be used for other magnetic applications.

PLEASE READ INSTRUCTIONS CAREFULLY!

PERFORMANCE DATA

MODEL	VOLTAGE	DC / mA	AC / mA	TERMINALS	Lb.	Kg.
1224	12 V	40	38	C & L	30	13.6
	24 V	40	36	C & H	30	13.6
24120	24 V	20	19	C & L	40	18.1
	120 V	-	20	C & H	35	15.8

HIGH HOLDING FORCE / SPECIAL APPLICATIONS:

MODEL	VOLTAGE	DC / mA	AC / mA	TERMINALS	Lb.	Kg.
1224	24 V	85	81	C & L	75	34.0
24120	120 V	-	100	C & L	110	49.8

To obtain performance values in table above, apply high listed voltage to low voltage terminals (C & L).

NOTE: This configuration can only be applied to Models 1224

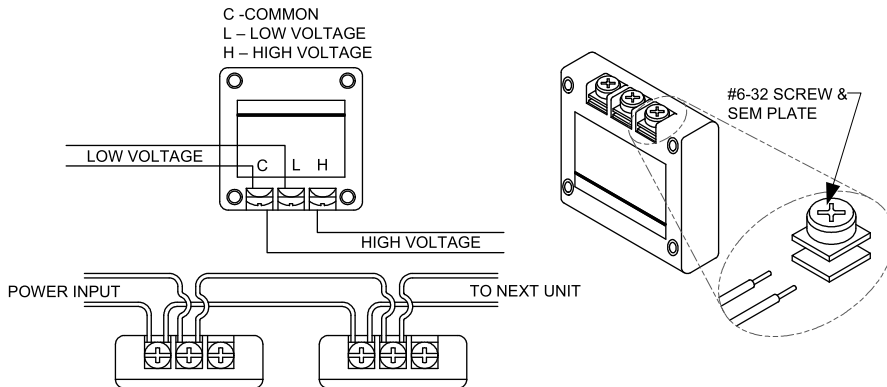

SURFACE MOUNTING

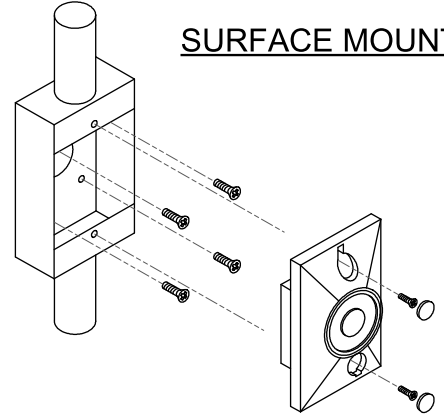

GENERAL MOUNTING

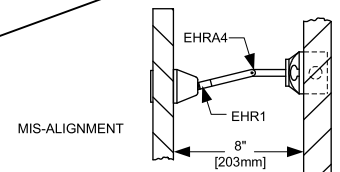
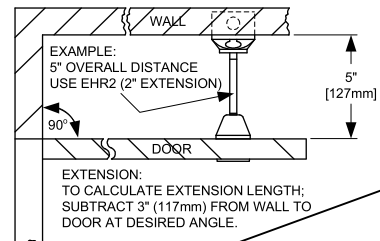
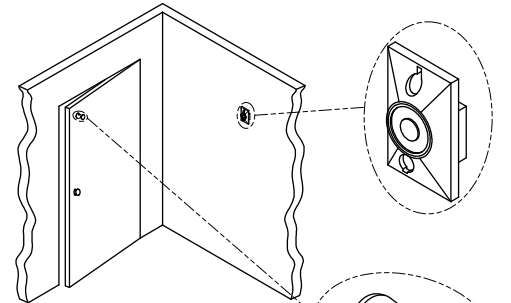

GENERAL DIMENSIONS

DOOR MAGNET

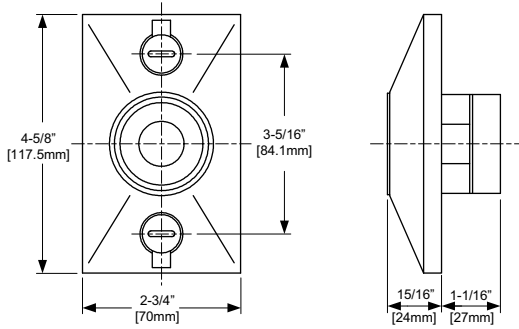

CATCH PLATE ASSEMBLY

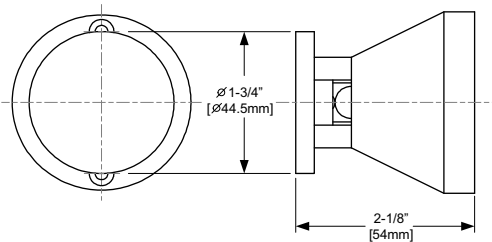

SURFACE MOUNT BACK BOX

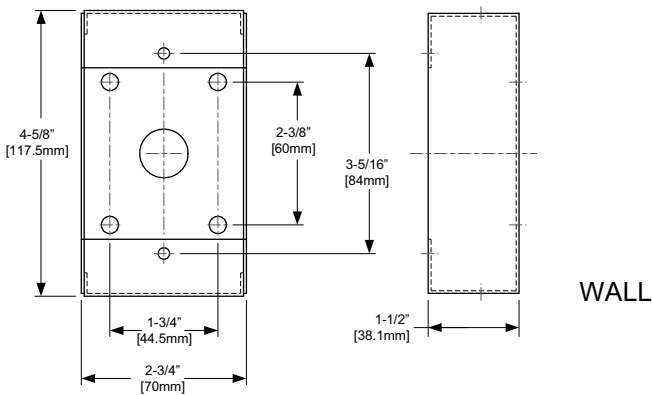

EXTENSION RODS

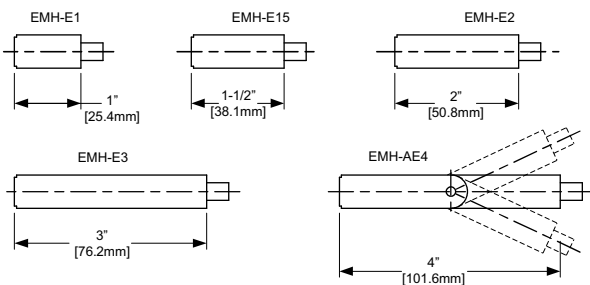

ASSEMBLY INSTRUCTIONS

CATCH PLATE MOUNTING

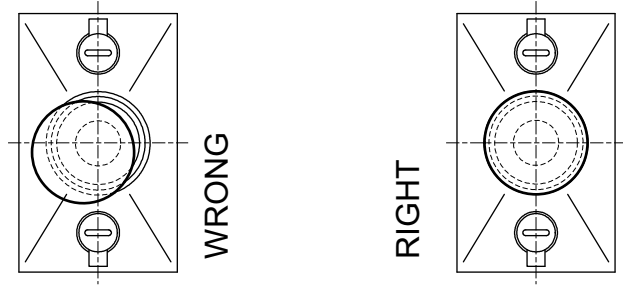

STEP 1:

With door magnet securely fastened, aligned and energized, proceed with swivel base assembly.

STEP 2:

Attach swivel portion to magnet, being careful to center the catch plate over the magnet.

NOTE: If door extensions are required, install before step 2.

STEP 3:

With catch plate assembly attached magnetically to door magnet, peel adhesive backing off mounting template and slide over catch plate, making sure adhesive side faces door.

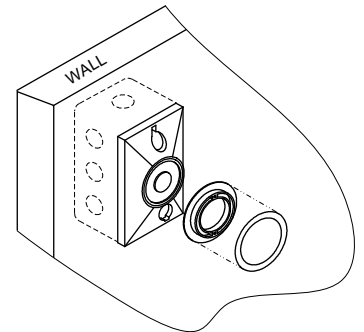

STEP 4:

Gently close door and with one hand adjust base of catch plate to lie flat against the door.

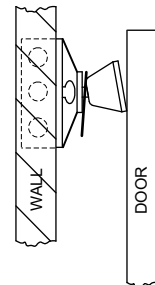

STEP 5:

While keeping slight pressure on door, slide mounting template over catch plate to door surface and apply pressure to template in a few spots.

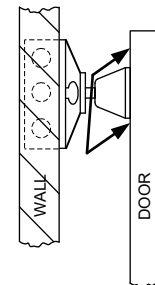

STEP 6:

Opening door will reveal mounting template. Apply final pressure to insure template does not fall off while assembly takes place.

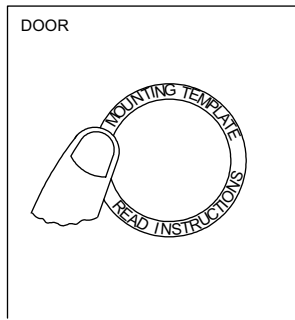

STEP 8C:

If mounting catch plate assembly directly to door, drill 1/8" dia. pilot hole approximately 1 to 1-1/2" deep, being careful not to go through door.

STEP 9:

For either style of mounting (thru door/direct) remove **ONLY** alignment template, then place swivel in center. Align holes, then insert screws and tighten assembly fully. Lastly, remove mounting template.

STEP 7:

Insert alignment template into center of mounting template. Use tab to rotate to fine adjustment. While holding alignment template with one hand, remove adhesive backing of tab, then push flat against door.

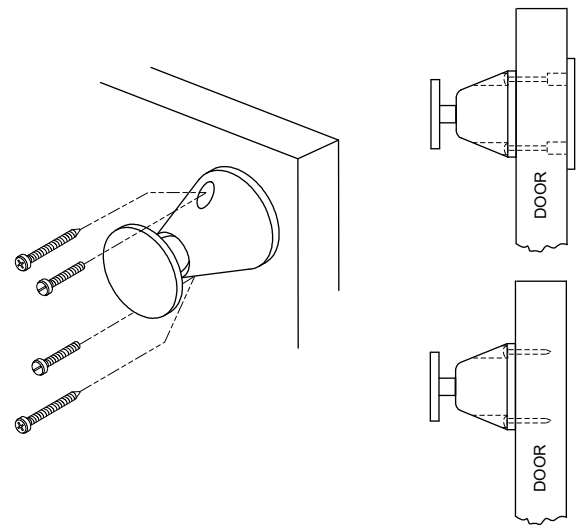
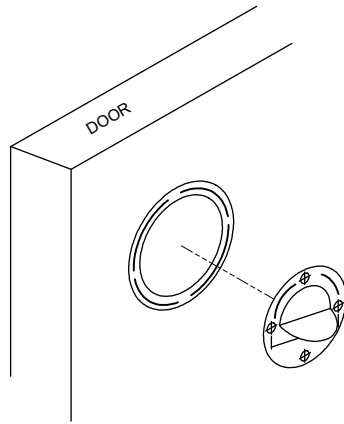

STEP 8 A:

If not using door assembly drill fixture, center punch points indicated on alignment template for either horizontal or vertical mounting. For best results, drill 1/8" pilot holes first, then follow with 5/16" dia drill.

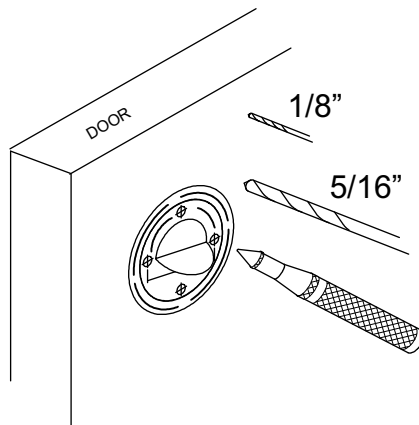

CATCH PLATE EXTENSION ROD ASSEMBLY:

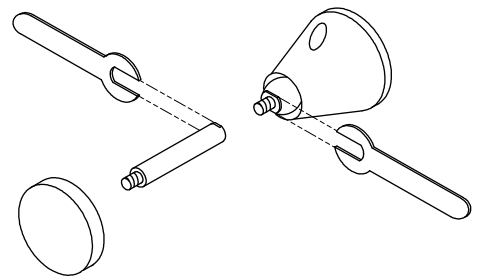

STEP 8 B:

If using door assembly drill fixture, alignment template is not required. Locate drill bushing end into mounting template, holding firmly flat against door, then tighten slightly. Make sure fixture is flat against edge of door, tighten fully and drill through using 5/16" dia. drill.

